

DILLON

RIFLE COMPANY



OWNERS MANUAL | TAC 501

Dillon Rifle Company
21605 N. 7th Ave.
Phoenix, AZ 85027
© Copyright 2023 Dillon Rifle Co.

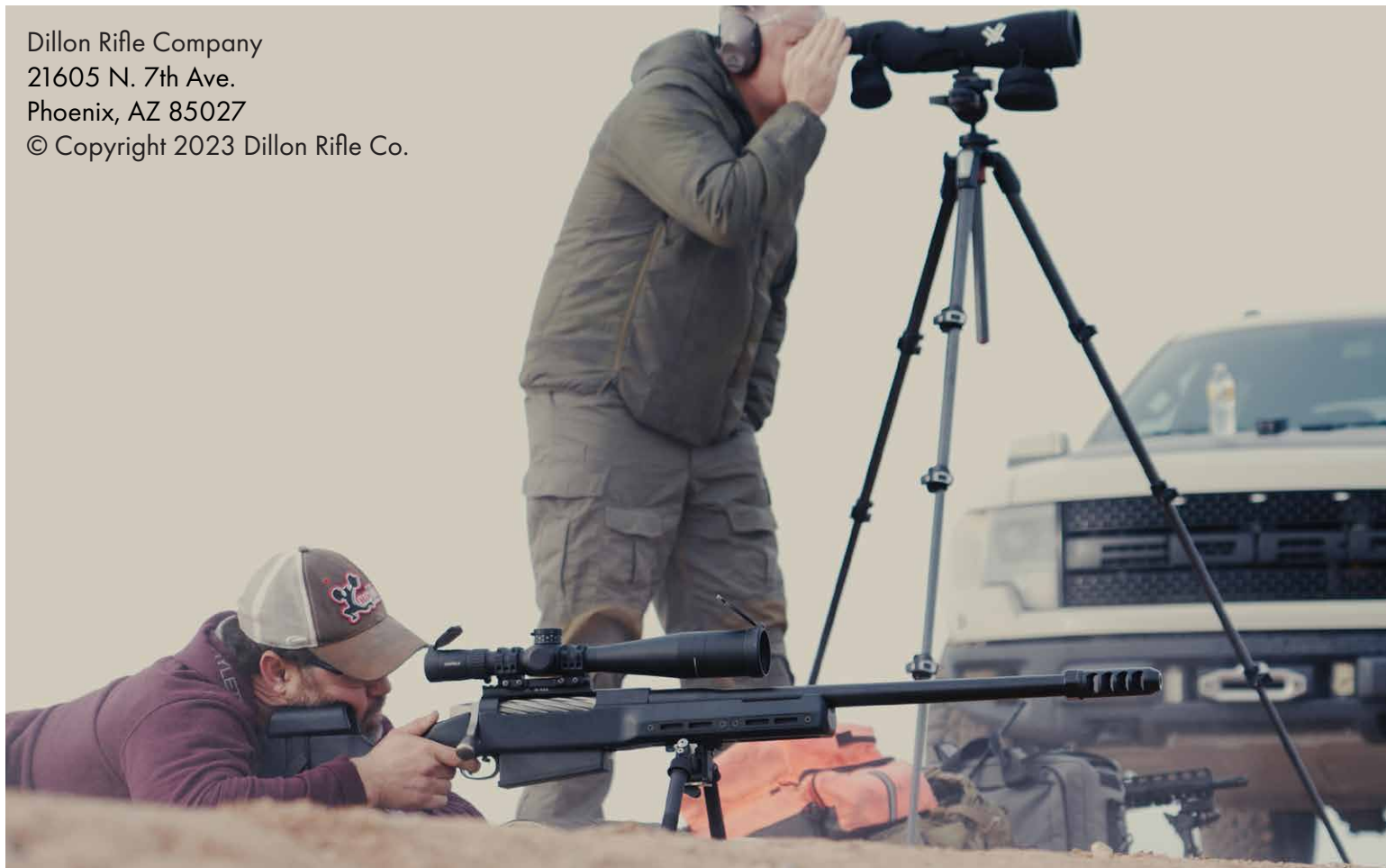

Thank you for choosing Dillon Rifle Company.

The TAC 501 is the result of 30 years of firearms development and production. Please take some time to review the user manual to become acquainted with the weapon.





TABLE OF CONTENTS

Equipment Introduction	6
Preparation for Use	8
New Rifle Break-In Procedure	11
Assembly	13
Rifle System Controls	15
Barrel Inspection	17
Rifle Maintenance	18
Operating Procedures	21
Bolt Maintenance	27
Parts & Service	29
Parts List	31
Warranty	45



EQUIPMENT INTRODUCTION



Rifle Purpose:

The Dillon Rifle Company TAC 501 rifle provides the tactical and competitive shooter with a professional grade rifle.

Description:

The TAC 501 rifle system is a heavy barrel, manually operated, detachable box magazine with five shot capacity. It is fitted with a custom built Grayboe carbon fiber stock, equipped with a spacer system and adjustable cheek rest. The rifle system rests on an B&T Atlas bipod.

The system utilizes a Remington 700 style trigger set to 4.5 lbs with a bottom safety. The 27.5" barrel is a match grade stainless steel barrel with a 1 in 15 twist. The barreled action comes with a black Cerakote finish or natural stainless finish using a clear coat and nickel finish.

The TAC 501 rifle system is capable of shooting sub-MOA accuracy with a trained marksman and match grade ammunition.

PREPARATION FOR USE

SAFETY RULES:

WARNING: READ THESE BASIC SAFETY RULES

Learn how to handle your rifle safely. Failure to follow these rules can result in serious personal injuries or death. Only you can prevent accidents.

Know Your Firearm:

To use it correctly and safely, read and follow the instructions in this manual.

- 1.** Treat ALL firearms as if they are loaded.
- 2.** Never point your firearm at anything you are not willing to destroy.
- 3.** Keep your finger off the trigger until your sights are on target and you are ready to fire.
- 4.** Be sure of your target! Know what is in front of and behind the target.
- 5.** Never make changes to/or alter any parts in your rifle, especially the trigger. Use only original Dillon Rifle Company rifle parts.
- 6.** Make yourself safe at all times by wearing eye protection, such as shooting glasses or impact resistant sunglasses, when shooting. Wear ear protection, such as ear plugs or earmuffs, if not both. Repeated exposure to shooting noise can cause permanent hearing loss.

7. Take care of your rifle system and keep the barrel and muzzle brake clean and free of obstruction. Keep the rifle clean and have it checked periodically to verify and maintain proper function. Any worn, missing, or damaged parts may cause an unsafe condition resulting in possible injury or death.

8. Use only ammunition that exactly matches the type marked on your firearm. Handloads can be dangerous. Dillon Rifle Company is not responsible for any accidents or damage caused by handloads or improperly loaded ammunition. If for any reason the bolt closes with difficulty or increased effort, **“DO NOT FIRE THE RIFLE!”** If fired, the bolt may become stuck and require excessive means to open, causing possible damage to the rifle.

9. Never load a firearm until you are in a location where it is safe to fire and you are ready to shoot.

10. Know the range of your firearms! Remember, centerfire bullets can travel out to 5.5 miles.

11. If a firearm fails to fire, keep it pointed in a safe direction, wait one minute and carefully unload, avoiding exposure to the breech. If the firearm discharges, but the report or recoil seems weak, unload and ensure there are no barrel obstructions.

12. Unload your firearm whenever you are not shooting. Never carry or store a loaded firearm in a building or vehicle. Unload your firearm before climbing up or over a fallen obstacle, fence, or slippery area.

13. Store your firearm and ammunition safely, especially away from children. Lock unloaded firearms and ammunition securely in separate locations.

NEW RIFLE BREAK-IN PROCEDURES

CAUTION: Never drink alcoholic beverages before or during shooting.

For the best results and longest life of your rifle barrel, we suggest the following break-in procedure.

1. Thoroughly clean the barrel before shooting. We recommend a good quality bronze brush, coated cleaning rod, bore guide, brass jag, and soft clean patches. As for solvents, for initial cleaning we prefer a good copper fouling remover. Note that ammonia type fouling removers are caustic and can cause damage if left on surfaces. Follow all warning labels on any solvent or cleaners used.

2. Start by pushing a patch wet with solvent through the bore. If you have a bore guide, it can significantly help with the cleaning process. Run the patch all the way through and out the muzzle. Do not reverse direction of the brush while it is still in the barrel. Perform this for twenty (20) strokes with a solvent soaked brush and patch. After the twenty (20) strokes, run a dry patch in the same manner until the patch comes out clean. Once clean and dry, the rifle is now ready to shoot.

3. WARNING: Before firing the rifle, make sure that the barrel and the muzzle brake are clean and free of any obstruction, and NEVER fire the rifle without the muzzle brake.

(Cont'd)

4. Fire one to five rounds and reclean the bore as stated in step 2. In order to break in the barrel correctly it is critical to remove all traces of fouling. After the initial bore cleaning has been completed, run several patches soaked in copper fouling remover completely through the barrel. Dry patch after each wet patch. Once there is no trace of copper in the bore and the patches come out clean and dry, fire the next round. Repeat this procedure again.

5. Although it isn't necessary; if further cleaning and break-in is desired, it is recommended that you perform a two (2) shot cadence and clean until totaling twenty (20) rounds.

6. CAUTION: Do not use any kind of abrasive cleaner in the bore of your rifle.

7. To continue to get the best accuracy and longest life from your custom barrel, we recommend that you clean the barrel every 30-40 shots.

ASSEMBLY OF THE DILLON TAC 501

RIFLE SYSTEM:

1. Your Dillon Rifle Co. TAC-501 Tactical Rifle System can be broken down into two major components: the stock assembly and the action/barrel assembly.

2. Remove the stock and make sure there is no grit, dust, or any foreign matter in the recoil lug recess or bedding (action) area. This is absolutely critical to achieve accuracy.

3. Carefully inspect the action/barrel assembly and check that it is clean and free of any foreign matter.

4. Gently place the action/barrel assembly into the stock. Be careful not to damage the bedding area.

5. Use the 5/16 x 24 hex socket to fasten the action/barrel to the stock assembly. **NOTE:** The short screw is

for the front, and the long screw is for the rear.

6. With the action/barrel assembly in place, use a torque wrench to tighten the screws to 80-85 inch-pounds. Always tighten the front screw first (the screw closest to the muzzle). This is accomplished when the handle "clicks," indicating the torque setting has been reached.

7. Insert the complete bolt assembly into the rear of the action. Ensure that the bolt stop clicks into the guide track in the bolt body.

8. Once the bolt is past the bolt release, you will have to depress the magazine follower to allow the bolt to go into battery.

BIPOD:

- 1.** Remove the bipod from the case/packing carton.
- 2.** Ensure that it is clean and free of any foreign matter, especially in the latches and spigot area.
- 3.** Attach the bipod using the supplied M-Lok compatible picatinny rail.
- 4.** Attaching the Atlas bipod will require loosening the lower cam lever to rotate the bipod to secure the bipod to the rail. The tensioning wheel allows the user to secure the bipod in the preferred shooting position by adding tension to the cam lever.

RIFLE SYSTEM CONOTROLS

SAFETY LEVER:

1. The safety lever provides protection against accidental or unintentional discharge under normal usage when properly engaged.
2. To engage the safety, move the safety lever to the rear (SAFE) position.
3. Always move the safety lever to the rear (SAFE) position before handling, loading, or unloading the rifle.
4. When you are ready to fire the rifle, move the safety lever to the forward (FIRE) position.
5. Avoid touching the trigger when moving the safety lever.



BOLT ASSEMBLY:

Removal of the Bolt Assembly:

1. Point the rifle in a safe direction.
2. Move the safety lever to the rear (SAFE) position.
3. Avoid touching the trigger while moving the safety lever.
4. Loosen and remove the cheek rest from the stock.
5. Raise the bolt handle.
6. Pull the bolt all the way to the rear.
7. Depress the bolt stop release.
8. As you depress the bolt stop release, slide the bolt from the rifle. The butt stock may have to be removed for clearance.



Installation of the Bolt Assembly:

1. Point the rifle in a safe direction.
 2. Move the safety lever to the rear (SAFE) position.
 3. Align the lugs on the bolt at 12 and 6 o'clock.
- NOTE:** If the unloaded magazine is installed, the user must depress the follower to slide the bolt forward.
4. Slide the bolt assembly into the receiver approximately halfway and rotate it until the bolt stop/guide clicks into its track.
 5. To lock the bolt assembly into position, push the bolt handle down.
 6. Re-install the cheek rest.

BARREL INSPECTION

Barrel Inspection Procedure:

1. Point the rifle in a safe direction.
2. Move the safety lever to the rear (SAFE) position.
3. Raise the bolt handle.
4. Pull the bolt all the way to the rear.
5. Remove any ammunition from the chamber and/or magazine.
6. Remove the bolt.
7. Look through the barrel from the chamber end to the muzzle.

To Remove an Obstruction From Inside the Barrel:

8. Use the correct size cleaning rod.
9. Push the cleaning rod from the chamber end all the way through the barrel until the rod comes out of the muzzle. Verify the muzzle brake is free of patches and other debris.
10. If an object cannot be easily pushed out of the barrel with a cleaning rod, return the rifle to Dillon Rifle Company.

NEVER try to remove an object from the barrel by loading another cartridge and firing.

RIFLE MAINTENANCE

Moly Coated or Copper Jacketed Bullets

Clean the rifle after 30 to 40 rounds in order to maintain "benchrest accuracy."

Removing & Installing the Muzzle Brake

1. The rifle can be cleaned with the muzzle brake on or off.
2. Removing and re-installing the muzzle brake should only be done by a trained gunsmith.

Cleaning Procedure

1. Ensure the rifle is unloaded and pointed in a safe direction.
2. Remove the magazine, cheek rest, and bolt from the rifle.

3. Roll one patch all the way around the brass jag. The cotton patch should be 4"x6" for maximum effect. Wet the patch with solvent. Roll the cleaning rod with the wet patch in the chamber and neck area.

4. Unroll approximately 2" of the wet patch, leaving the other 2/3rds on the jag. Push the remaining wet patch through the bore and remove it at the muzzle.

5. Replace the brass jag with the phosphor bronze brush, wet it with solvent and run it through the barrel and out the muzzle. Once the brush is forward of the muzzle, detach the brush, remove the cleaning rod, and re-attach the brush to continue cleaning. Do this a total of ten (10) times. After the tenth time, reapply the bore solvent and run the brush back through another ten (10) times. (Up and back is one time.)

NOTE: NEVER reverse the brush while inside the bore.

6. Replace the bronze brush with the brass jag and roll a 4"x4" patch on to the jag. Dry patch the bore until the patches come out clean and dry.

7. Roll a 4"x4" patch onto the jag. Wet the patch with copper fouling remover and push it through the bore and out the muzzle. Remove the old patch. Repeat once more and clean up with dry patch. Repeat this process until all copper fouling is removed. Once all fouling has been removed from the barrel, dry patch the chamber, neck, and bore until clean and dry.

WARNING: Ammonia-based solvents should never be left in the barrel for more than 5 minutes, as they could permanently etch the bore.

NOTE: Do not ever use any type of copper fouling remover on bronze brushes. It will attack them the same as fouling in the bore. Copper remover may be used with a nylon brush for heavily fouled barrels.

8. Wrap a 4" square patch around the jag. Wet the patch with boresolvent (not copper remover) and run it through the bore, followed by one or two dry patches. Copper fouling removers will leave the bore dry and totally stripped of any oil. Many standard bore cleaners/solvents have some traces of oil that will stay in the bore.

9. The barrel should now be clean and the rifle ready to fire or store.

NOTE: For barrels using moly coated bullets, additional cleaning may need to be done to remove the moly fouling.

LUBRICATION PROCEDURES

Cleaning the Receiver and Trigger Assembly

1. Wipe the rifle down with a clean soft cloth. A thin coat of light oil may be applied to all steel surfaces. Apply gun grease (non melting grease, not heavy oil) at the rear of the locking lugs located at the front of the

bolt, and the cocking cam located at the rear-under-side. Keep grease from getting into the trigger as this may create an unsafe condition. Do not over lube.

2. When the rifle is to be stored, it should be carefully cleaned and thoroughly oiled. A soft 1" paint brush may be used to clean dust and dirt from hard to reach areas. The bore should be coated with a very light layer of oil. Avoid over oiling the bore as it will work its way down into the action.

3. When the rifle is to be reused, all excess lubrication must be removed. The chamber and the bore must be thoroughly cleaned and wiped dry.

NOTE: NEVER use WD-40 on any part of the rifle. WD-40 is a water displacing oil and will dry out, leaving a sticky varnish behind.

OPERATING PROCEDURES

Loading the Magazine and Chamber

1. Point the rifle in a safe direction.
2. Move the safety lever to the rear (SAFE) position.
3. Raise the bolt handle.
4. Pull the bolt all the way to the rear.
5. Insert the required number of cartridge into the magazine.
6. Load the magazine into the rifle, insert one cartridge into the chamber while depressing the cartridges in the the magazine to allow the bolt to slide forward.
7. Finish closing the bolt on the cartridge you inserted into the chamber.

THE RIFLE IS NOW LOADED

8. To fire the rifle, move the safety lever to the forward (FIRE) position.

THE RIFLE IS NOW READY TO FIRE



Loading a Single Cartridge Only

1. Point the rifle in a safe direction.
2. Move the safety lever to the rear (SAFE) position.
3. Raise the bolt handle.
4. Pull the bolt all the way to the rear.
5. Insert one cartridge through the loading/ejection port and into the magazine.
6. Push the bolt forward and chamber the cartridge. Lock the bolt closed.
7. If you choose to insert the round directly into the chamber, the magazine follower must be depressed to allow the bolt to move forward. Once depressed the bolt may be closed over the chambered round.

WARNING: Always check the cartridge for the correct headstamp which matches the rifle. NEVER force the bolt closed on a cartridge. If extra effort is ever needed to close the bolt, stop. Open the bolt, remove and discard the round. Failure to do so may result in damage to the firearm and injury or death to the shooter.

THE RIFLE IS NOW LOADED

8. To fire the rifle, move the safety lever to the forward (FIRE) position.

THE RIFLE IS NOW READY TO FIRE

Unloading Unfired Rounds from the Rifle

- 1.** Point the rifle in a safe direction.
- 2.** Move the safety lever to the rear (SAFE) position.
- 3.** Raise the bolt handle.
- 4.** Pull the bolt all the way to the rear.
- 5.** Observe the round being extracted from the rifle, and remove the magazine.

CARE AND CLEANING PROCEDURES

Cleaning the Receiver and Trigger Assembly

1. Move the safety lever to the rear (SAFE) position.
2. Remove the bolt assembly.
3. Turn the rifle upside down
4. Remove the two action screws.
5. Carefully lift the stock away from the receiver and trigger assembly.

NOTE: Clean the receiver and trigger assembly as a unit with a degreaser. Do not leave any degreaser on coated surfaces any longer than necessary.

6. Wipe the receiver down with a light coat of oil. Let stand for 15 minutes, then wipe or blow off all excess lubricant with a clean rag or air.

7. Before replacing the bolt, make sure the barrel is free from obstructions. Grease bolt as per step 1.

8. After cleaning the trigger assembly, double check to be sure there are no cartridges in the rifle, close the bolt, move the safety lever to the forward (FIRE) position, and pull the trigger. The firing pin must fall. Repeat at least 5 times.

WARNING: If the firing pin does not remain cocked, when the bolt is closed smartly, return the rifle to Dillon Rifle Company.

9. Cleaning should also be performed after long term storage, or after being subjected to rain, sleet, dust, snow, sand, mud or saltwater.

Cleaning the Bolt Assembly

- 1.** Remove the bolt assembly from the rifle.
- 2.** Use a good quality solvent and a rag to wipe down the bolt body. Ensure that all fouling and residue are removed.
- 3.** With a good quality bristle brush and solvent scrub the bolt face and remove all fouling and loose brass from the bolt face.
- 4.** Lift the extractor upward and clean under the extractor notch with the brush and solvent.
- 5.** Dry thoroughly and lubricate bolt body with a small amount of gun oil.
- 6.** Activate the ejector and the extractor and ensure they move freely without sticking.
- 7.** If the ejector or the extractor sticks, return the rifle to Dillon Rifle Company.
- 8.** A light film of grease should be applied behind the bolt locking lugs. **DO NOT OVER GREASE.** This will facilitate smooth bolt movement and less grease will be needed as the rifle is broken in.

BOLT MAINTENANCE PROCEDURES

BOLT MAINTENANCE

1. Remove the bolt from the receiver.
2. Hold the bolt in your left hand with the bolt handle towards you, bolt face to the left, cocking piece housing to the right, and with the cocking piece facing up.
3. Holding the bolt firmly in your left hand, grasp the cockingpiece housing with your right hand, and give the cocking piece housing a 1/8 turn away from you (clockwise). This unlocks the firing pin assembly from the bolt.



4. While still holding the bolt in your left hand, pull the firing pin assembly out to the right. Then lay the bolt body aside.

5. Remove all grease, dirt, powder residue, and solvents from the firing pin assembly and inside bolt body.

6. To reinstall the firing pin assembly, first apply grease at both locking tabs located on the cocking piece housing. Grasp the bolt with your left hand with the back of the bolt facing to the right. Install the firing pin assembly into the back of the bolt while aligning housing tabs with the notches in the bolt body. When aligning the tabs, the cocking

piece should be positioned to the right of the cocking cam and notch (Recommend using a non-marring, hard surface to press the bolt against.). With the palm of your right hand, firmly press the firing pin assembly in until it bottoms out on the rear of the bolt. Once fully depressed, rotate the firing pin assembly counter clockwise.

7. You will feel the firing pin assembly lock in place.

8. Grease the locking lugs and cocking cam of the bolt. Install bolt in receiver making certain the bolt stop/guide has “clicked” into its track in the bolt body.



PARTS AND SERVICE

To Order Parts:

1. Go to our website dillonriflecompany.com
2. To order by phone call: 480-573-3110
Please have the following information ready before you call.
 - Firearm model and serial number.
 - Part description and quantity. Part descriptions can be found on the parts listing page in this manual.
 - Your complete mailing address (P.O. Box and street address) including zip code, telephone number and e-mail address.
 - Method of payment: Card number and expiration date. A quote may be made to you over the phone.
(Sorry, no C.O.D.s.)

WARNING! USE ONLY DILLON RIFLE CO. PARTS IN DILLON RIFLE CO. FIREARMS.

Repair Services:

1. Contact Dillon Rifle Company if your firearm needs servicing. Please call 480-573-2110, Mon-Fri., 8:00 a.m. to 4:00 p.m. Arizona time.
2. If shipment of your firearm is required, please:
 - Record the serial number of your firearm and scope before sending it to us.
 - Remove all accessories from the firearm to prevent loss or damage.
 - Pack your firearm for safety and to prevent damage in shipping and handling in a firearms box. (Please email us a picture of the complete kit to include the rifle and scope to: info@dillonriflecompany.com)

(Cont'd)

- Enclose a letter with the firearm detailing the model name or number of your firearm and serial number along with a full description of the problem. Be sure to include your full name and address (P.O. Box and Street Address), including zip code, daytime telephone number and e-mail address.

- Ship your firearm using FedEx ground service with adult signature. We want to track your rifle.

Ship To:

McMillan Firearms Manufacturing
Attn: Rifle Service Division/Repairs
23606 N 19th Ave. Suite 12
Phoenix, Arizona 85085

WARNING! DO NOT SEND LIVE AMMUNITION IN YOUR FIREARM OR IN THE SAME BOX WITH THE FIREARM. THIS IS A VIOLATION OF FEDERAL LAW. IF YOU FEEL YOU MUST SEND AMMUNITION, PLEASE SEND THEM IN A SEPARATE PACKAGE AND INCLUDE NAME, ADDRESS (WITH ZIP CODE) TELEPHONE NUMBER, MODEL AND SERIAL NUMBER OF YOUR FIREARM.

PARTS LIST AND GAUGES

Dillon Rifle Co. TAC 501, .50 Cal Tactical Repeater Rifle

Part Number:	Description:	Qty:
02-00027	Action, Barreled, Heavy, w/ Trigger, TAC 501, Assembly	1
02-00025	Action, Barreled, Heavy, TAC 501	1
02-00022-00	Action, TAC 501, Assembly	1
02-00011-00	Natural Stainless w/ NP3 Coat	1
01-00062-00	Receiver, Blank, Dillon TAC 501	1
01-00063-00	Stop, Bolt, TAC 501	1
08-00010-07	Pin, Dowel, .125 DIA., .625 LG.	1
11-00020-00	Spring, Compression, .120 OD, .022 Wire, .375 fl	1
02-00021-00	Bolt, TAC 501, Assembly	1
01-00082	Bolt, TAC 501	1
01-00083-00	Extractor, TAC 501	1
01-00084-00	Plunger, Extractor, TAC 501	1
11-00022-00	Spring, Compression, .120 OD, .024 wire, .625 fl.	1
01-00085-00	Ejector, TAC 501	1
11-00021-00	Spring, Compression, .180 OD, .032 Wire, 1.125 fl.	1
08-00009-05	Pin, Slotted Spring, .094 DIA., Steel	1

PARTS LIST AND GAUGES (Cont'd.)

Dillon Rifle Co. TAC 501, .50 Cal Tactical Repeater Rifle

Part Number:	Description:	Qty:
02-00023-00	Pin, Firing, TAC 501, Assembly	1
01-00087-00	Pin, Firing, TAC 501	1
01-00086-00	Shroud, Cocking Piece, TAC 501	1
01-00088-00	Cocking Piece, TAC 501	1
11-00023-00	Spring, Compression, .590 OD, .067 X .125 Oval, 3.00 fl.	1
08-00012-02	Screw, Set, Cup Tip, 4-40, .250 Lg.	1
01-00089-00	Knob, Bolt, Teardrop, TAC 501	1
02-00024-00	Lug, Recoil, TAC 501	1
01-00090-00	Lug, Recoil, TAC 501	1
08-00010-03	Pin, Dowel, .125 DIA., .375 Lg.	1
01-00091	Barrel, Heavy, Match, TAC 501	1
07-00003	Muzzle Break, Gen 2 XXX Bastard APA	1
07-00004	Trigger, REM700, 510-V2B, Timney, Assembly	1
08-00010-08	Pin, Dowel, .125 DIA., .750 Lg.	2
02-00028	Magazine Release, TAC 501, Assembly	1
01-00094-00	Housing, Magazine Lever, TAC 501	1

PARTS LIST AND GAUGES (Cont'd.)

Dillon Rifle Co. TAC 501, .50 Cal Tactical Repeater Rifle

Part Number:	Description:	Qty:
01-00095-00	Lever Magazine, TAC 501	1
08-00010-07	Pin, Dowel .125 DIA., .625 Lg.	1
11-00003-00	Spring, Compression, .180 OD. .032 Wire, .375 fl.	1
08-00013-12	Screw, Socket Cap, Hex, 8-32	2
01-00093-00	Stock, TAC 501, Grayboe, Assembly	1
01-00096	Trigger Guard, TAC 501	1
01-00097-00	Rail 30 MOA, STD Lg, Blk, TAC 501	1
01-00143	1913 Rail, M-LOK, 7-Slot	1
08-00016-01	Screw, Button Head, Hex, 10-24, .375 Lg.	2
01-00144	Nut, M-LOK	2
08-00013-06	Screw, Socket Cap, Hex, 8-32	6
08-00015-06	Screw, Socket Cap, Hex, .3125-24, 1.250 Lg.	2

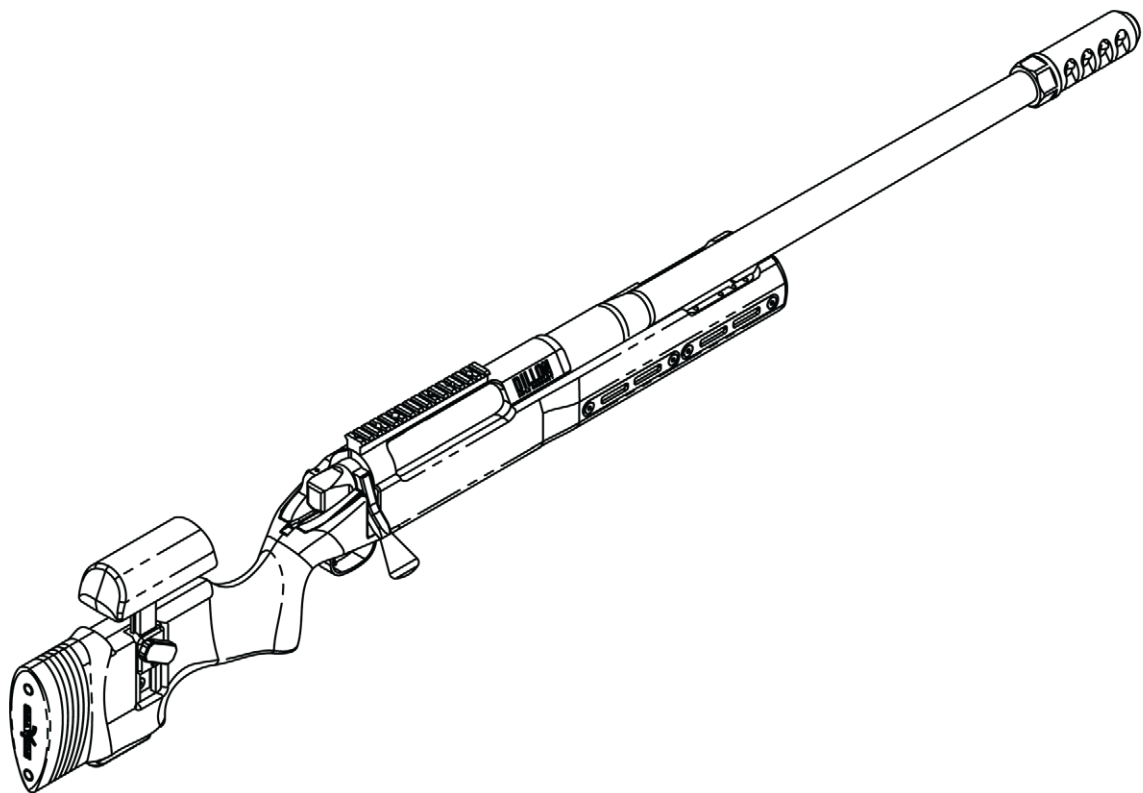

TAC 501 ASSEMBLY (BARRELED, HEAVY W/ TRIGGER)

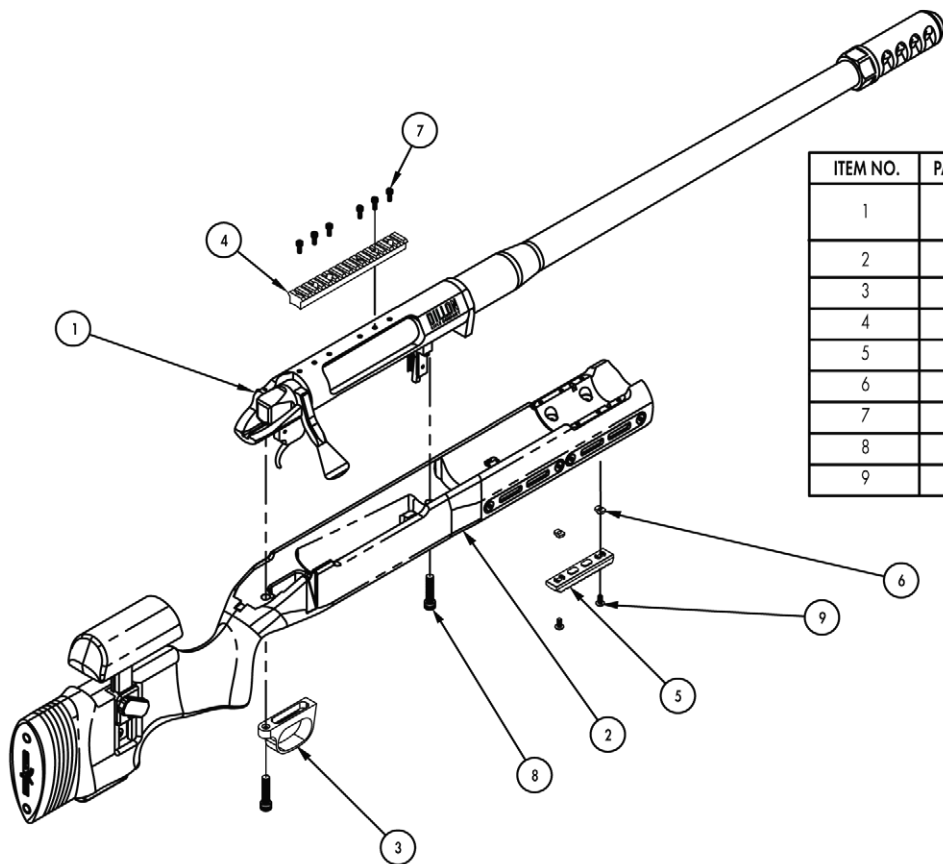

ITEM NO.	PART NUMBER	DESCRIPTION	QTY.
1	02-00027	ACTION, BARRELED, HEAVY, W/ TRIGGER, TAC 501, ASSEMBLY	1
2	01-00093-00	STOCK, TAC 501, GRAYBOE, ASSEMBLY	1
3	01-00096	TRIGGER GUARD, TAC 501	1
4	01-00097-00	RAIL, 30 MOA, STD LG, BLK, TAC 501	1
5	01-00143	1913 RAIL, M-LOK, 7-SLOT	1
6	01-00144	NUT, M-LOK	2
7	08-00013-06	SCREW, SOCKET CAP, HEX, 8-32	6
8	08-00015-06	SCREW, SOCKET CAP, HEX, .3125-24, 1.250 LG	2
9	08-00016-01	SCREW, BUTTON HEAD, HEX, 10-24, .375 LG	2

TAC 501 | RECEIVER

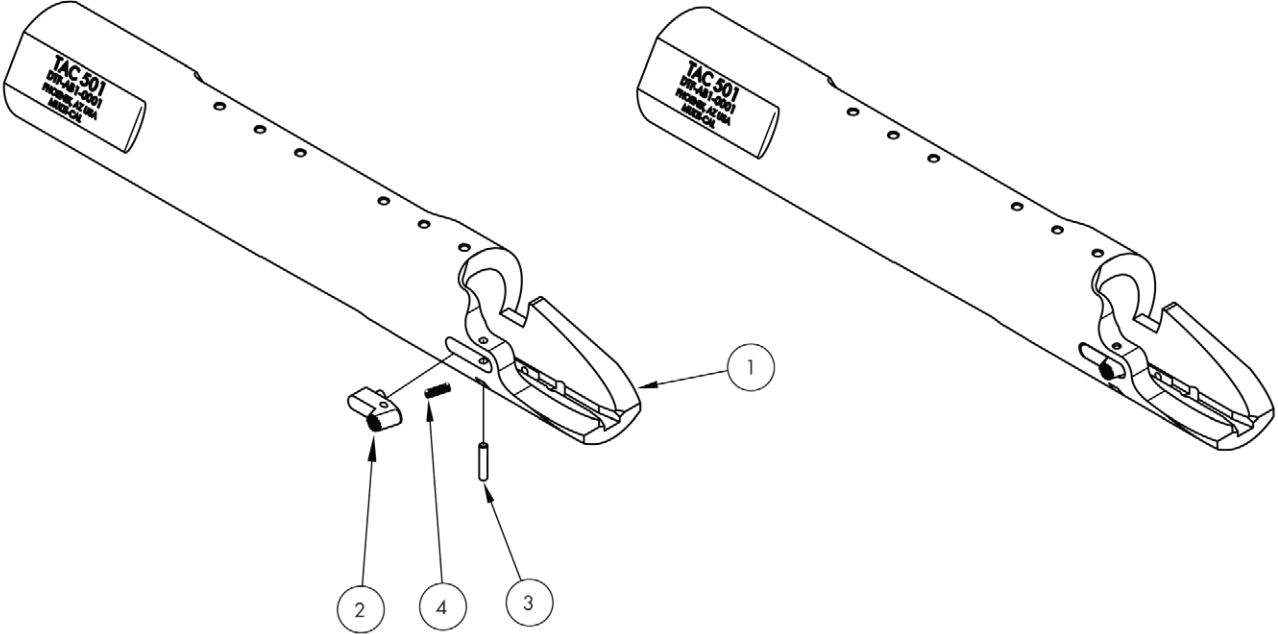

ITEM NO.	PART NUMBER	DESCRIPTION	QTY.
1	01-00062-00	RECEIVER, BLANK, DILLON TAC 501	1
2	01-00063-00	STOP, BOLT, TAC 501	1
3	08-00010-07	PIN, DOWEL, .125 DIA., .625 LG.	1
4	11-00020-00	SPRING, COMPRESSION, .120 OD, .022 WIRE, .375 FL	1

TAC 501 | ACTION

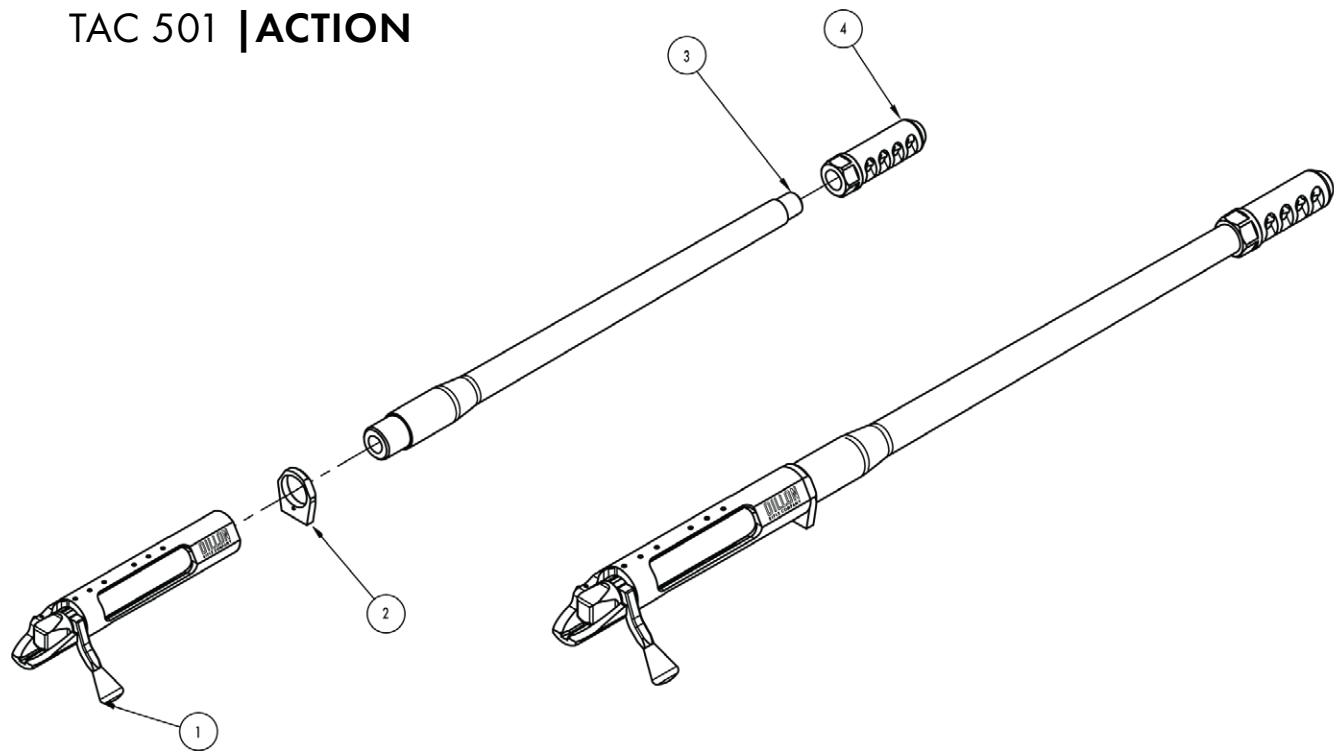

ITEM NO.	PART NUMBER	DESCRIPTION	QTY.
1	02-00022-00	ACTION, TAC 501, ASSEMBLY	1
2	02-00024-00	LUG, RECOIL, TAC 501	1
3	01-00091	BARREL, HEAVY, MATCH, TAC 501	1
4	07-00003	MUZZLE BREAK, GEN 2 XXX BASTARD APA	1

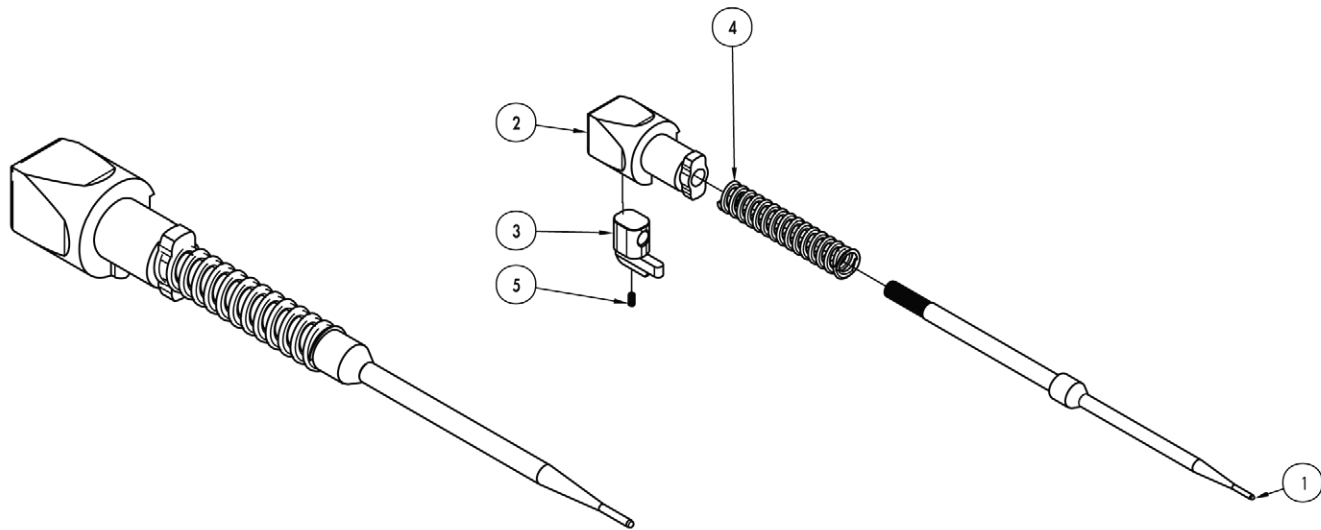

ITEM NO.	PART NUMBER	DESCRIPTION	QTY.
1	01-00087-00	PIN, FIRING, TAC 501	1
2	01-00086-00	SHROUD, COCKING PIECE, TAC 501	1
3	01-00088-00	COCKING PIECE, TAC 501	1
4	11-00023-00	SPRING, COMPRESSION, .590 OD, .067 X .125 OVAL, 3.00 FL	1
5	08-00012-02	SCREW, SET, CUP TIP, 4-40, .250 LG	1

TAC 501 | FIRING PIN

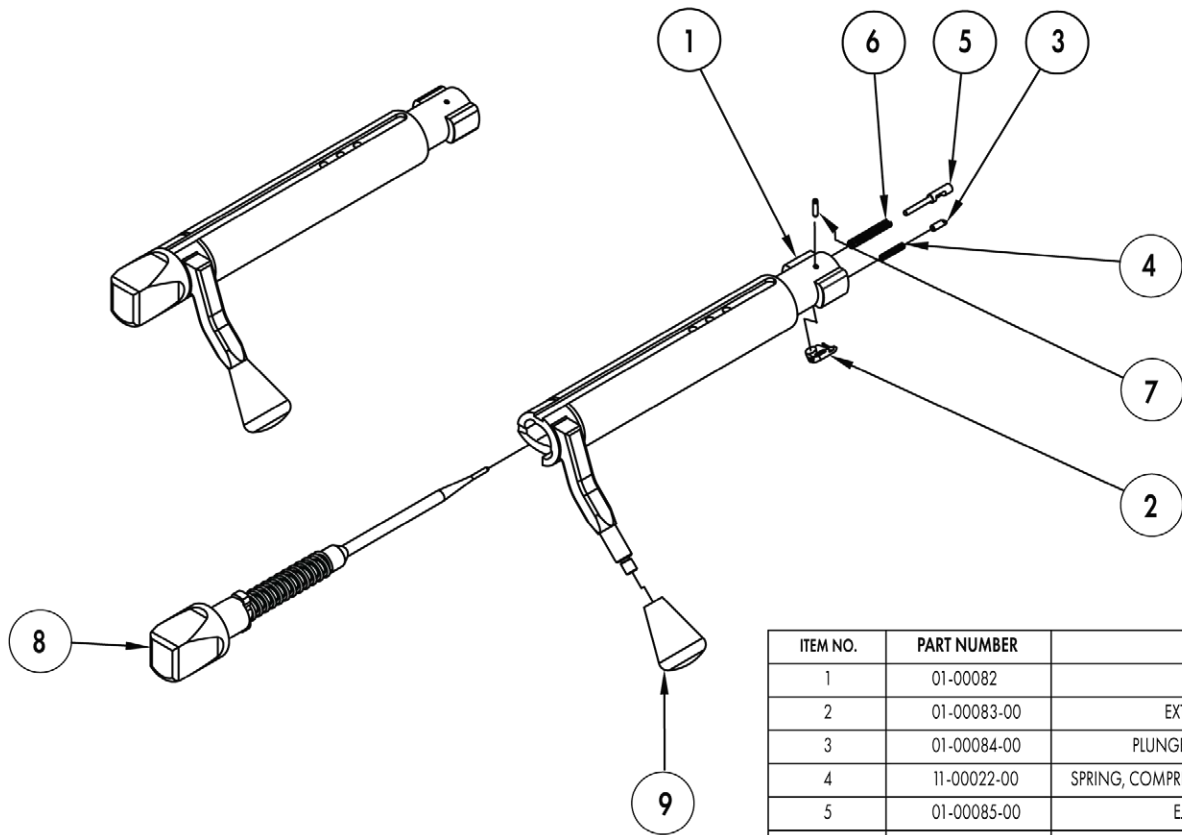

TAC 501 | BOLT

ITEM NO.	PART NUMBER	DESCRIPTION	QTY.
1	01-00082	BOLT, TAC 501	1
2	01-00083-00	EXTRACTOR, TAC 501	1
3	01-00084-00	PLUNGER, EXTRACTOR, TAC 501	1
4	11-00022-00	SPRING, COMPRESSION, .120 OD, .024 WIRE, .625 FL.	1
5	01-00085-00	EJECTOR, TAC 501	1
6	11-00021-00	SPRING, COMPRESSION, .180 OD, .032 WIRE, 1.125 FL.	1
7	08-00009-05	PIN, SLOTTED SPRING, .094 DIA., STEEL	1
8	02-00023-00	PIN, FIRING, TAC 501, ASSEMBLY	1
9	01-00089-00	KNOB, BOLT, TEARDROP, TAC 501	1

ITEM NO.	PART NUMBER	DESCRIPTION	QTY.
1	01-00094-00	HOUSING, MAGAZINE LEVER, TAC 501	1
2	01-00095-00	LEVER, MAGAZINE, TAC 501	1
3	08-00010-07	PIN, DOWEL, .125 DIA., .625 LG.	1
4	11-00003-00	SPRING, COMPRESSION, .180 OD, .032 WIRE, .375 FL.	1

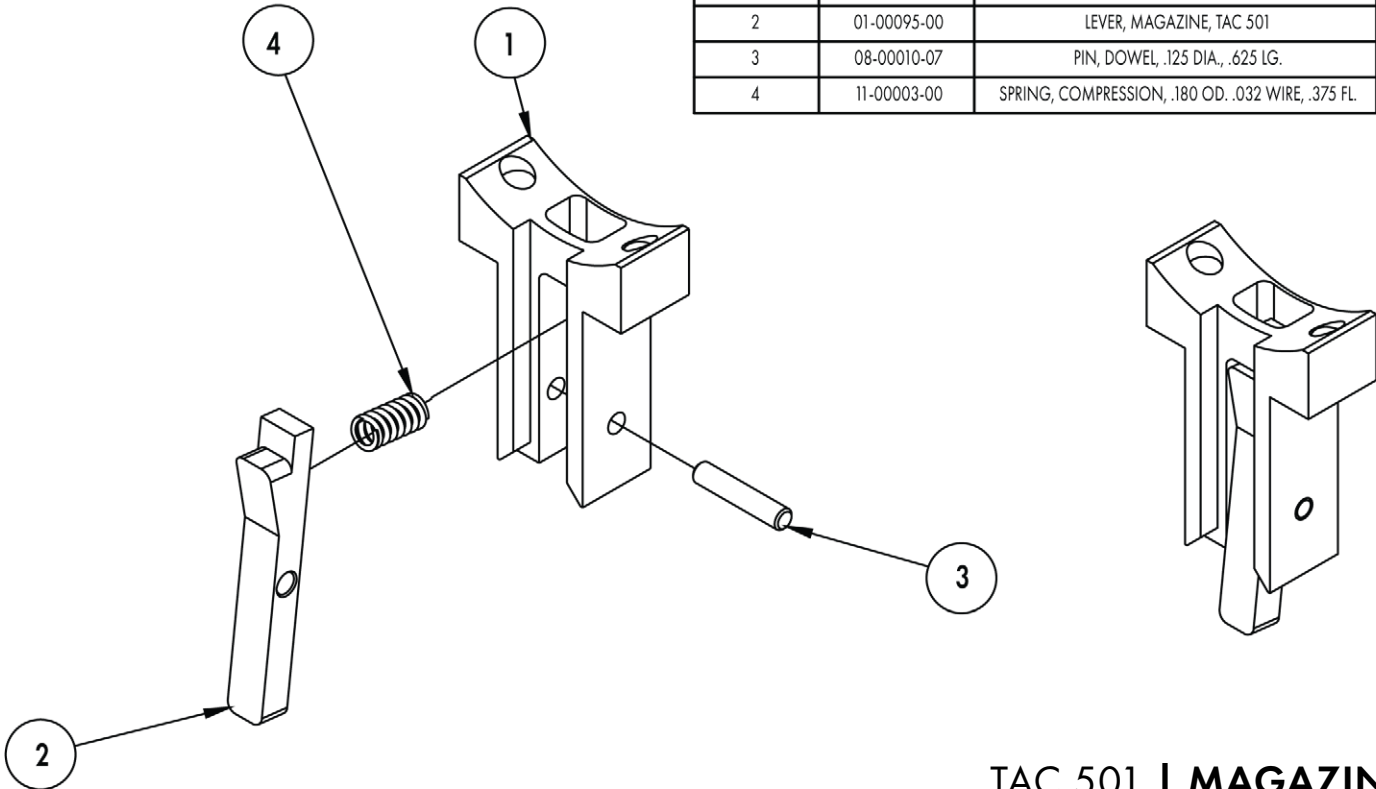

TAC 501 | **MAGAZINE LEVER**

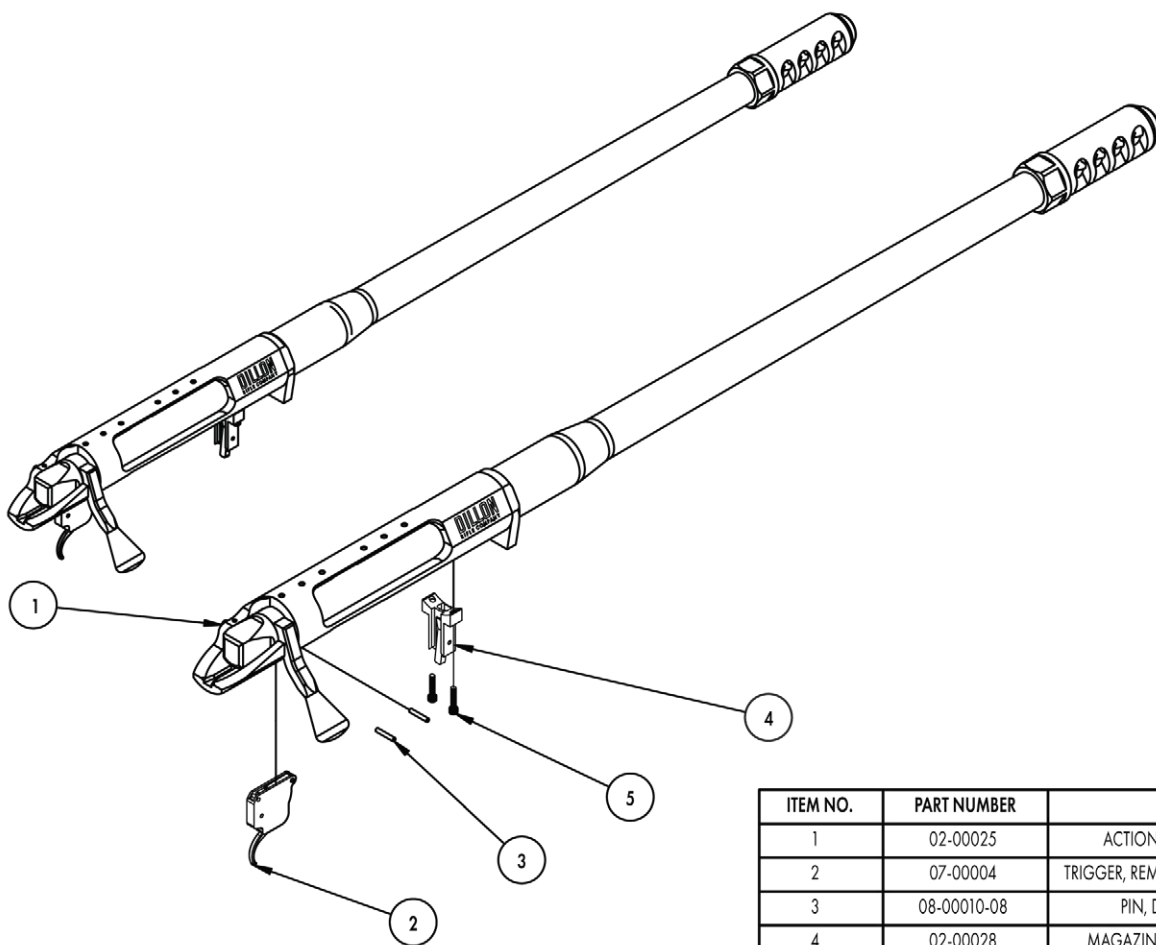

TAC 501 | ACTION

ITEM NO.	PART NUMBER	DESCRIPTION	QTY.
1	02-00025	ACTION, BARRELED, HEAVY, TAC 501	1
2	07-00004	TRIGGER, REM700, 510-V2B, TIMNEY, ASSEMBLY	1
3	08-00010-08	PIN, DOWEL, .125 DIA., .750 LG.	2
4	02-00028	MAGAZINE RELEASE, TAC 501, ASSEMBLY	1
5	08-00013-12	SCREW, SOCKET CAP, HEX, 8-32	2

ADDENDUM

NOTE: THE MAGAZINES FROM THE TAC-50 AND THE TAC-501 A1/A1-R2 ARE NOT INTERCHANGEABLE

Magazine System:

1. Release the magazine from the rifle by pressing forward on the magazine release lever located at the front of the trigger guard.
2. The magazine should drop freely.

Installing Magazine:

1. With the bolt opened and to the rear, insert the magazine into magazine well and press up until an audible click is heard and the magazine release lever is engaged properly.
2. Pull down on the magazine to ensure proper locking.

DON'T ALTER OR MODIFY YOUR RIFLE AND HAVE IT SERVICED REGULARLY.

Your firearm has been designed to operate according to certain factory specifications. You'll jeopardize your safety and that of others around you by attempting to alter its trigger, mechanical safety or other mechanisms. So never alter or modify your firearm in any way.

Like any mechanical device, a firearm is subject to wear. It must be maintained and periodically serviced to assure optimum safety and performance. Only Dillon Rifle Company should service, repair or modify your Dillon Rifle Company firearm. Consult your instruction book for instructions on how to send your firearm to Dillon Rifle Company. Dillon Rifle Company recommends that you have your

firearm professionally serviced annually. You should also have your firearm professionally serviced after prolonged storage, or if there is ever any question pertaining to the proper functioning characteristics of your firearm.

Proper cleaning and lubrication are also important to firearm maintenance and are necessary to assure accuracy, safety and reliability. Before cleaning, always make sure that your gun is completely unloaded. And always clean the barrel from the chamber end to the muzzle when possible.

Contact: Dillon Rifle Co.
21605 N. 7th Ave.
Phoenix, AZ 85027
info@dillonriflecompany.com

FIREARM OWNER'S RECORD

Model _____

Serial # _____

Date Purchased _____

Purchased From _____

Price Paid _____

WARRANTY

TO LEARN HOW MUCH CONFIDENCE
A COMPANY HAS IN ITS PRODUCTS,
READ ITS WARRANTY.

100% Guaranteed Satisfaction

Every DRC rifle carries an "Unconditional Lifetime Warranty" against manufacturing defects. This does not include normal "wear and tear" of the firearm including barrel life, internal components and damages resulting in operator misuse. If a problem occurs with the firearm, which is covered under warranty, the defective item will be repaired or replaced.

OR

If for any reason you are not 100% satisfied with your DRC rifle, return it within 30 days of purchase in good condition for a full refund or exchange.

Items that are purchased but are not manufactured by DRC, such as scopes and cases, are not covered under the DRC warranty.



www.dillonriflecompany.com